

## Standard Pressure Regulators

Description	Supply pressure max. bar	Pressure range bar	Connection thread	Device	Page
„Maxi“-Series, robust, interlockable	21	0.2 ... 1.8 / 17	G $\frac{1}{4}$ - G1	R20, R21	<b>2.02</b>
made of plastic, also for liquids	12,5	0 ... 4 / 12	G $\frac{1}{8}$ - G1	R035 ... R095	<b>2.03</b>
with external feedback	16	0.2 ... 7.0	G $\frac{1}{4}$	R218	<b>2.04</b>
„Midi“-Series	21	0.2 ... 1.8 / 17	G $\frac{1}{4}$ - G $\frac{1}{2}$	R10, R11	<b>2.05</b>
extremely robust, high flow rate	21	0.2 ... 1.8 / 17	G $\frac{1}{4}$ - G3	R119	<b>2.06</b>
Series „D“, made of aluminium /die-cast zinc	30	0.2 ... 1.5 / 15	G $\frac{1}{8}$ - G2	RD	<b>2.08</b>
with joint supply	16	0.1 ... 3 / 16	G $\frac{1}{8}$ - G $\frac{1}{2}$	RB, R035	<b>2.10</b>
gauge pressure regulator	25	0.1 ... 3 / 16	G $\frac{1}{4}$ and G $\frac{3}{8}$	RM	<b>2.11</b>
270° adjustment dial pressure regulator	21	0 ... 3 / 11	G $\frac{1}{4}$ - G2	R11 ... R41	<b>2.12</b>



# 2

## Standard Regulators

Standard



2

# "Maxi" Pressure Regulator

R20 / R21

<b>Description</b>	Piston-operated high-capacity regulator of modular design with exchangeable inserts. Can be interlocked with filter or lubricator without double nipples. Each "maxi" regulator may be taken from a fixed line in seconds simply by removing the mounting bolts.	
<b>Media</b>	compressed air or non-corrosive gases	
<b>Supply pressure</b>	max. 21 bar	
<b>Adjustment</b>	R20: by plastic knob with snap-lock	R21: by T-handle with locknut
<b>Relieving function</b>	relieving, optionally non-relieving	
<b>Gauge port</b>	G $\frac{1}{4}$ on both sides of the body, screw plugs supplied	
<b>Mounting position</b>	any	
<b>Temperature range</b>	R20: 0 °C to 50 °C / 32 °F to 122 °F	R21: 0 °C to 80 °C / 32 °F to 176 °F
<b>Material</b>	Body: zinc die-cast Spring cage: zinc die-cast, adjusting knob made of with glass fibre-reinforced plastic Elastomer: NBR/Buna-N Inner valve: brass and plastic	

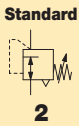
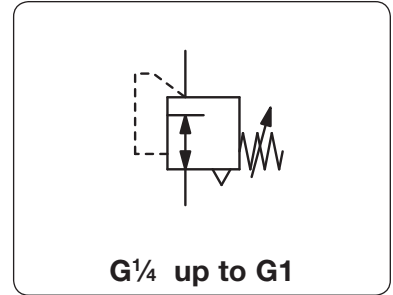

Dimensions			K <sub>v</sub> -value (m <sup>3</sup> /h)	Flow rate		Connection thread G	Pressure range bar	Order number
A	B	C		m <sup>3</sup> /h*1	l/min*1			

"Maxi" pressure regulator							supply pressure max. 21 bar, relieving, without pressure gauge	R20
89	162	38	3.4	240	4000	G $\frac{1}{4}$	0.2 ... 1.8 0.2 ... 4.0 0.3 ... 9.0 0.5 ... 17	R20-02A R20-02B R20-02C R20-02D
89	162	38	4.2	300	5000	G $\frac{3}{8}$	0.2 ... 1.8 0.2 ... 4.0 0.3 ... 9.0 0.5 ... 17	R20-03A R20-03B R20-03C R20-03D
89	162	38	5.2	372	6200	G $\frac{1}{2}$	0.2 ... 1.8 0.2 ... 4.0 0.3 ... 9.0 0.5 ... 17	R20-04A R20-04B R20-04C R20-04D
111	162	38	6.1	432	7200	G $\frac{3}{4}$	0.2 ... 1.8 0.2 ... 4.0 0.3 ... 9.0 0.5 ... 17	R20-06A R20-06B R20-06C R20-06D
111	162	38	6.3	450	7500	G1	0.2 ... 1.8 0.2 ... 4.0 0.3 ... 9.0 0.5 ... 17	R20-08A R20-08B R20-08C R20-08D



## Special options, add the appropriate letter

<b>T-handle</b>	including locknut	R21-0..
<b>NPT</b>	connection thread	R2.-0..N
<b>non-relieving</b>	without relieving function	R2.-0..K

## Accessories

<b>pressure gauge</b>	Ø 63 mm, 0...*2 bar, G $\frac{1}{4}$ up to 16 bar	<b>MA6302-...*2</b>
<b>mounting bracket</b>	Ø 63 mm, 0...25 bar, G $\frac{1}{4}$ up to 25 bar	<b>MA6302-...25</b>
<b>mounting nut</b>	assembly at spring cage	<b>BW45-02</b>
<b>set of brackets</b>	made of plastic	<b>M45x1,5K</b>
	made of aluminium	<b>M45x1,5A</b>
	made of steel	<b>MK20-0100</b>

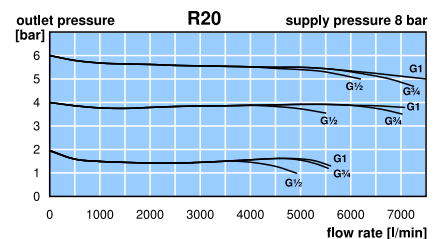
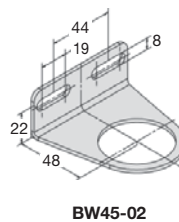
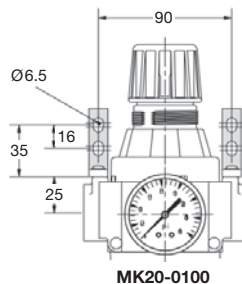
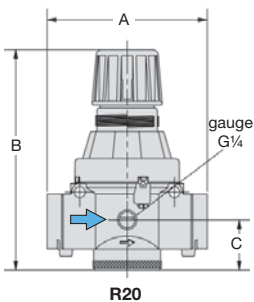

\*1 at 8 bar supply pressure, 6 bar outlet pressure and 1 bar pressure drop  
\*2 02 = 0...2.5 bar, 04 = 0...4 bar, 10 = 0...10 bar, 25 = 0...25 bar

Gauges: see chapter for measuring devices [www.aircom.net](http://www.aircom.net)

**Order example: R20-02A**

# Plastic Pressure Regulator

R035... R095

<b>Description</b>	Modular regulator easy to interlock with other regulators, filters or filter regulators of the same series, without the need for double nipples or any other fittings. A sensitive rolling diaphragm allows good pressure regulation.		
<b>Media</b>	compressed air, non-corrosive gases or liquids		
<b>Supply pressure</b>	max. 12,5 bar, max. 10 bar for R035, max. 16 bar bei R042		
<b>Adjustment</b>	by plastic knob with snap-lock, R035 without snap-lock		
<b>Relieving function</b>	relieving, optionally non-relieving		
<b>Gauge port</b>	G $\frac{1}{8}$ on both sides of the body (G $\frac{1}{4}$ at R095), one screw plug supplied		
<b>Mounting position</b>	any		
<b>Temperature range</b>	0 °C to 50 °C / 32 °F to 177 °F		
<b>Material</b>	Body: nylon, Elastomer: NBR/Buna-N Inner valve: brass Thread insert: brass	POM at R035 and R042	

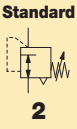
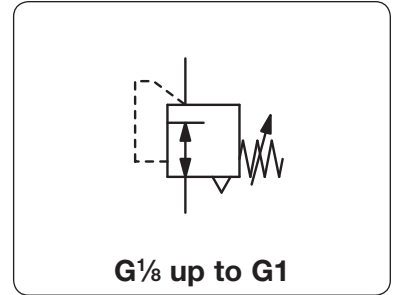

Dimensions			Kv-value (m <sup>3</sup> /h)	Flow rate		Connection thread G	Pressure range bar	Order number
A	B	C		m <sup>3</sup> /h*1	l/min*1			

Pressure regulator								supply pressure max. 12,5 bar, for series R035 max. 10 bar, for series R042 max. 16 bar, relieving, without pressure gauge	R0
36	61	12	0.11	15	250	G $\frac{1}{8}$	0... 6	R035-01B	
for battery assembly, see also catalogue page "regulator for joint supply"								0... 6	R035-01RB
42	102	20	0.36	51	850	G $\frac{1}{4}$	0... 4	R042-02B	
								0... 8	R042-02C
								0... 12	R042-02D
52	129	38	0.59	84	1400	G $\frac{3}{8}$	0... 4	R050-03B	
								0... 8	R050-03C
								0... 12	R050-03D
52	129	38	0.63	90	1500	G $\frac{1}{2}$	0... 4	R052-04B	
								0... 8	R052-04C
								0... 12	R052-04D
63	145	42	1.0	138	2300	G $\frac{1}{2}$	0... 4	R075-04B	
								0... 8	R075-04C
								0... 12	R075-04D
137	145	42	1.0	144	2400	G $\frac{3}{4}$	0... 4	R080-06B	
								0... 8	R080-06C
								0... 12	R080-06D
115	222	48	6.3	900	15000	G1	0... 4	R095-08B	
								0... 8	R095-08C
								0... 12	R095-08D



## Special options, add the appropriate letter

**non-relieving** without relieving function, also for liquids R0..-0..K

## Accessories

<b>pressure gauge</b>	Ø 23 mm, 0...*2 bar, G $\frac{1}{8}$ , max. 12 bar Ø 40 mm, 0...*2 bar, G $\frac{1}{4}$ Ø 50 mm, 0...*2 bar, G $\frac{1}{2}$ Ø 63 mm, 0...*2 bar, G $\frac{3}{4}$	for R035 for R042 for R050 to R080 for R095	<b>MA2301-...*</b> <b>MA4001-...*</b> <b>MA5001-...*</b> <b>MA6302-...*</b>
<b>mounting bracket</b>	made of steel, mounting nut at the device	for R042 for R050 to R080	<b>BW30-01</b> <b>BW42-01</b>
<b>set of brackets</b>	made of steel	for R095	<b>BW00-02</b>
<b>connection clips</b>		for R035	<b>C350100018</b>

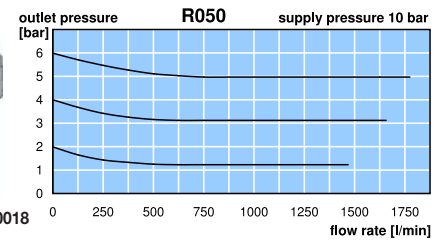
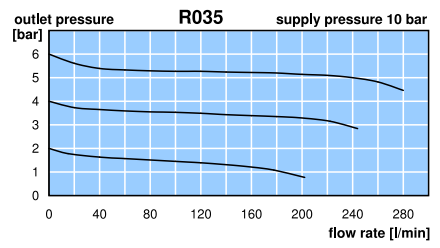
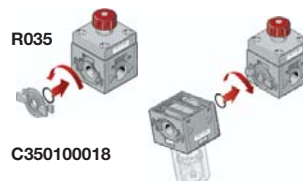
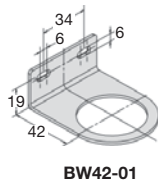
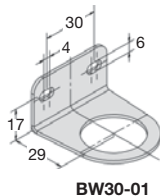
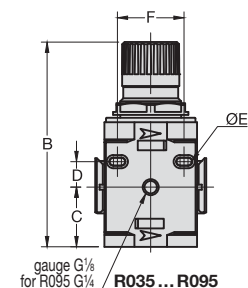

\*1 at 10 bar supply pressure, 6 bar outlet pressure and 1 bar pressure drop  
\*2 04 = 0...4 bar, 06 = 0...6 bar, 10 = 0...10 bar, 16 = 0...16 bar

# Pressure Regulator with External Feedback

R218

<b>Description</b>	Diaphragm pressure regulator in small design for "feedback systems" in conjunction with volume flow boosters. Due to the external feedback, regulation is significantly improved and the flow rate increased.			
<b>Media</b>	compressed air and non-corrosive gases			
<b>Supply pressure</b>	max. 16 bar	<b>Air consumption</b>	approx. 3 bis 6 l/min	
<b>Adjustment</b>	by handwheel with snap-lock, for panel mounting			
<b>External Feedback</b>	should be installed at the outlet of the booster, e.g. at the gauge port, or at the outlet pipe. This will measure the pressure drop at the output of the booster and the pilot pressure will be readjusted.			
<b>Relieving function</b>	relieving			
<b>Gauge port</b>	G $\frac{1}{4}$ on both sides of the body, screw plugs supplied	<b>Feedback connection</b>	G $\frac{1}{4}$	
<b>Temperature range</b>	0 °C to 60 °C / 32 °F to 140 °F		<b>Mounting position</b>	any
<b>Material</b>	Body: zinc die-casting	Spring cage: zinc die-casting	Elastomer: FKM	

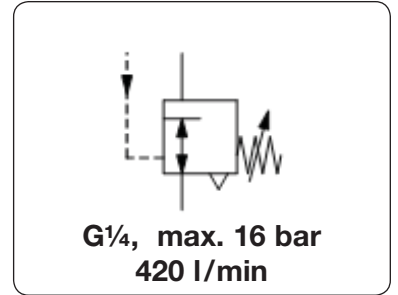

Dimensions			K <sub>v</sub> -value (m <sup>3</sup> /h)	Flow rate m <sup>3</sup> /h*1 l/min*1	Connection thread G	Pressure range bar	Order number
A	B	C					
mm	mm	mm					

Regulator with external feedback							supply pressure max. 16 bar, relieving, with air consumption		R218
82	154	19	0,3	25	420	G $\frac{1}{4}$	0.2 ... 7.0	R218-02C	



R218

## Accessories

pressure gauge	Ø 63 mm, 0 ... 10 bar, G $\frac{1}{4}$	MA6302-10
mounting bracket	made of steel	BW00-36
mounting nut	made of brass	M20x1,5M

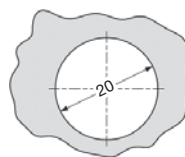

panel cut-out

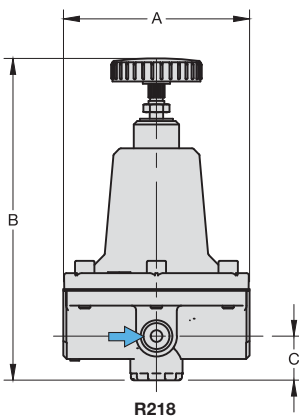

R218

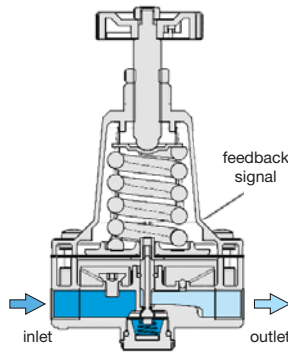

cross-section

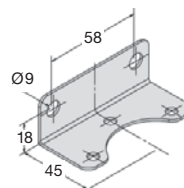

BW00-36

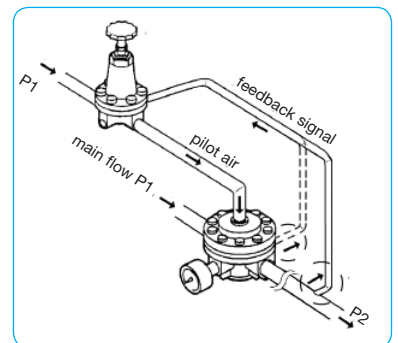

Example: combination with booster

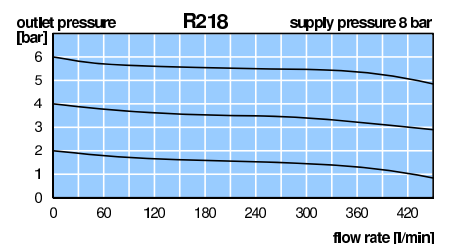

\*1 at 8 bar supply pressure, 6 bar outlet pressure and 1 bar pressure drop



# "Midi" Pressure Regulator

R10 / R11

<b>Description</b>	All-purpose, high-performance, diaphragm regulator with high flow.		
<b>Media</b>	compressed air or non-corrosive gases		
<b>Supply pressure</b>	max. 21 bar		
<b>Adjustment</b>	R10: by plastic knob with snap-lock R11: by T-handle with locknut		
<b>Relieving function</b>	relieving, optionally non-relieving		
<b>Gauge port</b>	G $\frac{1}{4}$ on both sides of the body, screw plug supplied		
<b>Mounting position</b>	any		
<b>Temperature range</b>	R10: 0 °C to 50 °C / 32 °F to 122 °F R11: 0 °C to 70 °C / 32 °F to 158 °F, for appropriately conditioned compr. air down to -30 °C / -22 °F		
<b>Material</b>	Body:	zinc die-cast	
	Spring cage:	glass fibre-reinforced plastic at R10,	zinc die-cast at R11
	Elastomer:	NBR/Buna-N, optionally FKM	Inner valve: brass, optionally stainless steel

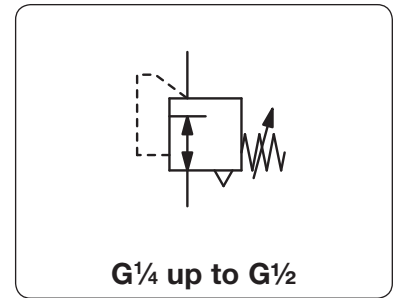

Dimensions			K <sub>v</sub> -value (m <sup>3</sup> /h)	Flow rate		Connection thread G	Pressure range bar	Order number
A	B	C		m <sup>3</sup> /h*1	l/min*1			

"Midi" pressure regulator			supply pressure max. 21 bar, relieving, without pressure gauge				R10	
60	124	35	1.8	132	2200	G $\frac{1}{4}$	0.2 ... 1.8	R10-02A
							0.2 ... 4.0	R10-02B
							0.3 ... 9.0	R10-02C
							0.5 ... 17	R10-02D
60	124	35	1.9	138	2300	G $\frac{3}{8}$	0.2 ... 1.8	R10-03A
							0.2 ... 4.0	R10-03B
							0.3 ... 9.0	R10-03C
							0.5 ... 17	R10-03D
60	124	35	2.0	144	2400	G $\frac{1}{2}$	0.2 ... 1.8	R10-04A
							0.2 ... 4.0	R10-04B
							0.3 ... 9.0	R10-04C
							0.5 ... 17	R10-04D



## Special options, add the appropriate letter

<b>T-handle</b>	including locknut	R11-0..
<b>NPT</b>	connection thread	R1.-0..N
<b>non-relieving</b>	without relieving function	R1.-0..K
<b>FKM elastomer</b>	inner parts made of brass	R1.-0..X64
	inner parts made of stainless steel	R1.-0..X08

## Accessories

<b>pressure gauge</b>	Ø 50 mm, 0...*2 bar, G $\frac{1}{4}$	up to 10 bar	MA5002-...*2
	Ø 50 mm, 0...25 bar, G $\frac{1}{4}$	up to 25 bar	MA5002-...25
<b>mounting bracket</b>	made of steel		BW45-01
<b>mounting nut</b>	made of plastic		M45x1,5K
	made of aluminium		M45x1,5A

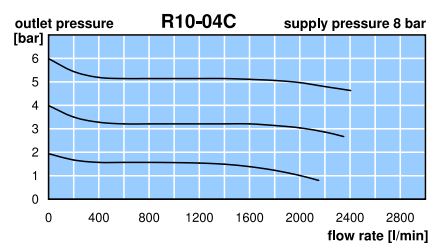
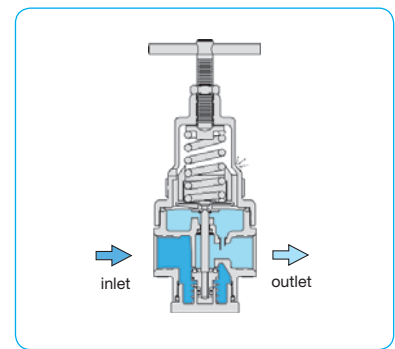
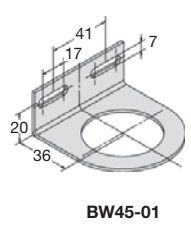
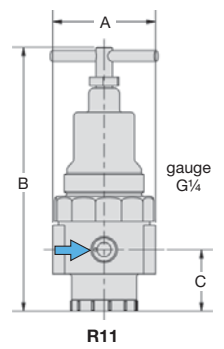
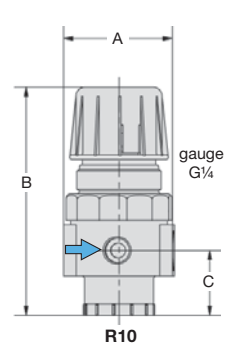

\*1 at 8 bar supply pressure, 6 bar outlet pressure and 1 bar pressure drop  
\*2 02 = 0...2.5 bar, 04 = 0...4 bar, 10 = 0...10 bar, 25 = 0...25 bar



# Standard Pressure Regulator

R119

**Description** High-capacity diaphragm regulator of solid design suitable for many applications. Ideal for installations where constant line pressure at wide flow variations. From size G2 on it is a pilot-operated piston regulator with an excellent regulation characteristic curve.

**Media** compressed air or non-corrosive gases

**Supply pressure** max. 21 bar

**Air consumption** from size G2 on the regulator's air consumption is about 0.1 l/min.

**Adjustment** by T-handle with locknut  
from size G2 on by plastic knob with snap-lock on the pilot regulator  
up to size G½ optionally by handwheel for control panel integration

**Relieving function** relieving, optionally non-relieving

**Gauge port** G¼ on both sides of the body, screw plugs supplied

**Temperature range** 0 °C to 50 °C / 32 °F to 122 °F, for appropriately conditioned compressed air down to -30 °C / -22 °F

**Material** Body: zinc die-cast  
Diaphragm: NBR/Buna-N

**Mounting position** any  
Inner valve: brass  
Bottom screw: reinforced nylon

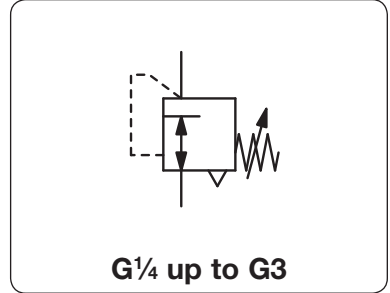

Standard  
2

Dimensions			Kv-value (m³/h)	Flow rate		Connection thread G	Pressure range bar	Order number
A	B	C		m³/h*1	l/min*1			

Standard pressure regulator						supply pressure max. 21 bar, relieving, without pressure gauge		R119
70	157	35	1.5	150	2500	G¼	0.2...1.8 0.2...4.0 0.3...9.0 0.5...17	R119-02A R119-02B R119-02C R119-02D
70	157	35	1.7	168	2800	G¾	0.2...1.8 0.2...4.0 0.3...9.0 0.5...17	R119-03A R119-03B R119-03C R119-03D
83	172	38	3.6	360	6000	G½	0.2...1.8 0.2...4.0 0.3...9.0 0.5...17	R119-04A R119-04B R119-04C R119-04D
113	265	49	5.4	540	9000	G¾	0.3...9.0 0.5...17	R119-06C R119-06D
113	265	49	6.0	600	10000	G1	0.3...9.0 0.5...17	R119-08C R119-08D

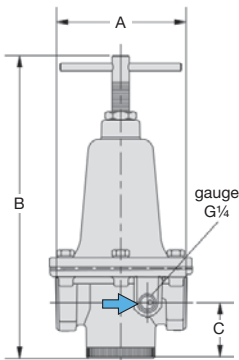

R119-02 ... -12

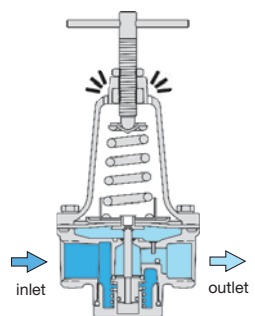

cross-section

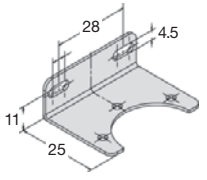

BW00-22

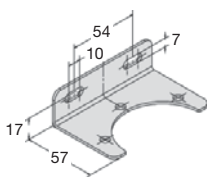

BW00-23

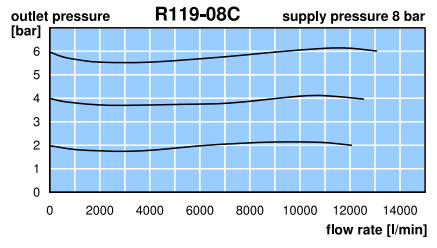
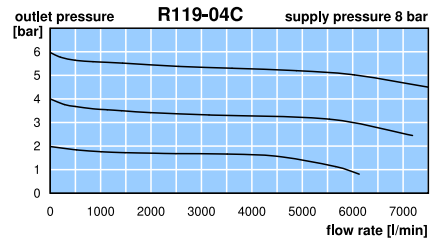
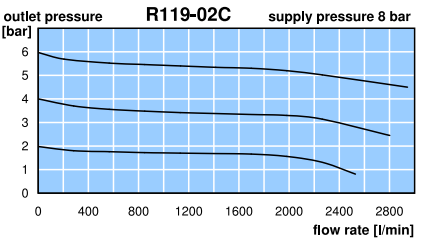

\*1 at 8 bar supply pressure, 6 bar outlet pressure and 1 bar pressure drop

PDF CAD  
www.aircom.net

Order example:  
R119-02A

<b>Description</b>	High-capacity diaphragm regulator of solid design suitable for many applications. Ideal for installations where constant line pressure at wide flow variations. From size G2 on it is a pilot-operated piston regulator with an excellent regulation characteristic curve.	
<b>Media</b>	compressed air or non-corrosive gases	
<b>Supply pressure</b>	max. 21 bar	
<b>Air consumption</b>	from size G2 on the regulator's air consumption is about 0.1 l/min.	
<b>Adjustment</b>	by T-handle with locknut from size G2 on by plastic knob with snap-lock on the pilot regulator up to size G½ optionally by handwheel for control panel integration	
<b>Relieving function</b>	relieving, optionally non-relieving	
<b>Gauge port</b>	G¼ on both sides of the body, screw plugs supplied	<b>Mounting position</b> any
<b>Temperature range</b>	0 °C to 50 °C / 32 °F to 122 °F, for appropriately conditioned compressed air down to -30 °C / -22 °F	
<b>Material</b>	Body: zinc die-cast Diaphragm: NBR/Buna-N	Inner valve: brass Bottom screw: reinforced nylon

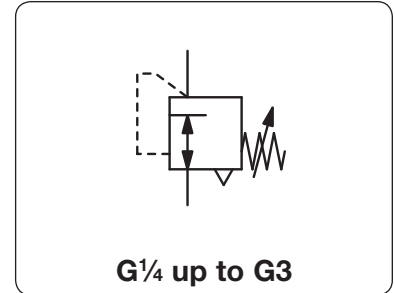

Dimensions			K <sub>v</sub> -value (m³/h)	Flow rate		Connection thread G	Pressure range bar	Order number
A	B	C		m³/h*1	l/min*1			
mm	mm	mm						

Standard pressure regulator								supply pressure max. 21 bar, relieving, without pressure gauge	R119
126	275	48	7.2	720	12000	G1½	0.3...9.0	R119-12C	
							0.5...17	R119-12D	
186	300	79	35.4	2520	42000	G2	0.2...1.8	R119-16A	
							0.2...4.0	R119-16B	
							0.3...9.0	R119-16C	
							0.5...17	R119-16D	
186	300	79	37.1	2640	44000	G2½	0.2...1.8	R119-20A	
							0.2...4.0	R119-20B	
							0.3...9.0	R119-20C	
							0.5...17	R119-20D	
214	360	95	56.0	6600	110000	G3	0.2...1.8	R119-24A	
							0.2...4.0	R119-24B	
							0.3...9.0	R119-24C	
							0.5...17	R119-24D	



Special options, add the appropriate letter		
<b>NPT</b>	connection thread	R119-...N
<b>non-relieving</b>	without relieving function	for G¼ to G2½ R119-...K for G3 R119-24.K
<b>FKM elastomer</b>		for G¼ to G1½ R119-...X64 for G3 R119-24.X64
<b>panel mounting</b>	with handwheel, hole diameter 16 mm	for G¼ to G½ R119-...P
<b>flange connection</b>	see chapter SST devices / flanges	R119-...F.
<b>PWIS-free</b>	for painting plants	R119-...LA

Accessories		
<b>pressure gauge</b>	Ø 50 mm, 0...*2 bar, G¼ Ø 63 mm, 0...*2 bar, G¼	for G¼ to G½ <b>MA5002-...*2</b> for G¾ to G2½ <b>MA6302-...*2</b>
<b>mounting bracket</b>	made of steel	for G¼ and G¾ <b>BW00-22</b> for G½ <b>BW00-23</b> for G¾ to G1½ <b>BW00-24</b>

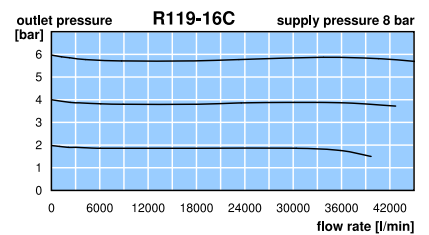
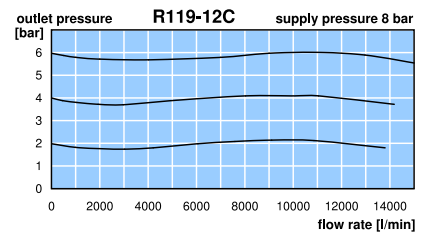
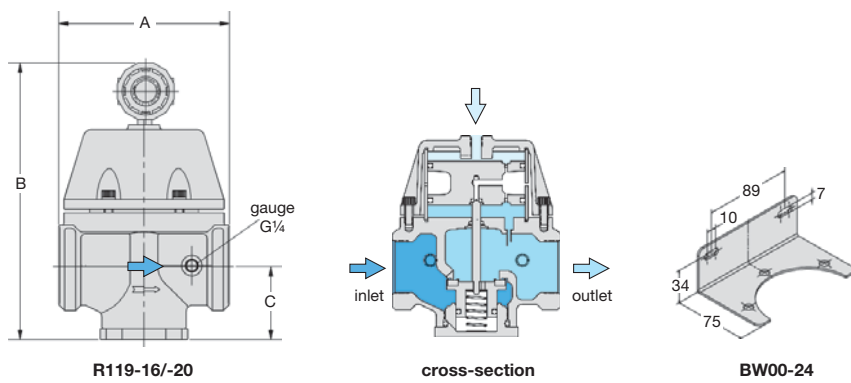

\*1 at 8 bar supply pressure, 6 bar outlet pressure and 1 bar pressure drop  
\*2 02 = 0...2.5 bar, 04 = 0...4 bar, 06 = 0...6 bar, 10 = 0...10 bar, 16 = 0...16 bar

**Description** Good value pressure regulator of solid design. RD1 and RD3 are equipped with diaphragms, RD4 is piston-operated. Wall mounting through two drilled holes in the bodies of RD1 to RD3.

**Media** compressed air or non-corrosive gases

**Supply pressure** max. 30 bar

**Adjustment** RD1/RD2: by plastic knob with snap-lock  
RD3: by handwheel  
RD4: by T-handle

**Relieving function** relieving, optionally non-relieving

**Gauge port** G $\frac{1}{4}$  on both sides of the body, G $\frac{1}{2}$  at RD1

**Mounting position** any

**Temperature range** -10 °C to 50 °C / 14 °F to 122 °F for RD1, RD2 and RD4  
-20 °C to 60 °C / -4 °F to 140 °F for RD3

**Material** Body: zinc die-cast at RD1, aluminium at RD2, RD3 and RD4  
Spring cage: plastic reinforced with glass fibre at RD1, nylon at RD2, aluminium at RD3/RD4  
Elastomer: NBR/Buna-N Inner valve: brass

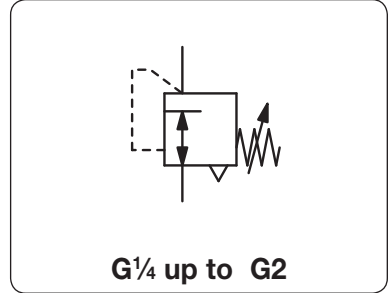

Dimensions			K <sub>v</sub> -value	Flow rate		P <sub>1</sub> max.	Connection thread	Pressure range	Order number
A	B	C		m <sup>3</sup> /h*1	l/min*1				

Pressure regulator										supply pressure max. 20 / 30 bar, relieving, without pressure gauge		RD1...RD4	
40	95	22	0.3	27	450	20	G $\frac{1}{2}$	0.2...1.5	RD1-01A				
								0.3...3.0	RD1-01B				
								0.5...8.0	RD1-01D				
								1.5... 15	RD1-01E				
40	95	22	0.3	27	450	20	G $\frac{1}{4}$	0.2...1.5	RD1-02A				
								0.3...3.0	RD1-02B				
								0.5...8.0	RD1-02D				
								1.5... 15	RD1-02E				
64	151	48	1.5	108	1800	20	G $\frac{3}{8}$	0.2...1.5	RD2-03A				
								0.3...3.0	RD2-03B				
								0.5...8.0	RD2-03D				
								1.5... 15	RD2-03E				
64	151	48	1.5	108	1800	20	G $\frac{1}{2}$	0.2...1.5	RD2-04A				
								0.3...3.0	RD2-04B				
								0.5...8.0	RD2-04D				
								1.5... 15	RD2-04E				
130	187	54	3.0	195	3250	30	G $\frac{3}{4}$	0.2...1.5	RD3-06A				
								0.3...3.0	RD3-06B				
								0.5...8.0	RD3-06D				
								1.5... 15	RD3-06E				
130	187	54	3.0	195	3250	30	G1	0.2...1.5	RD3-08A				
								0.3...3.0	RD3-08B				
								0.5...8.0	RD3-08D				
								1.5... 15	RD3-08E				
241	187	54	3.0	195	3250	30	G1 $\frac{1}{4}$	0.2...1.5	RD3-10A				
								0.3...3.0	RD3-10B				
								0.5...8.0	RD3-10D				
								1.5... 15	RD3-10E				
241	187	54	3.0	195	3250	30	G1 $\frac{1}{2}$	0.2...1.5	RD3-1AA				
								0.3...3.0	RD3-1AB				
								0.5...8.0	RD3-1AD				
								1.5... 15	RD3-1AE				



series	D	Ø E	M
RD1	30	4.5	M30x1,5
RD2	51	5.5	M50x1,5
RD3	76	6.5	-
RD4	76	8.5	-

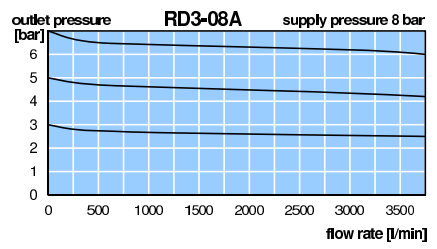
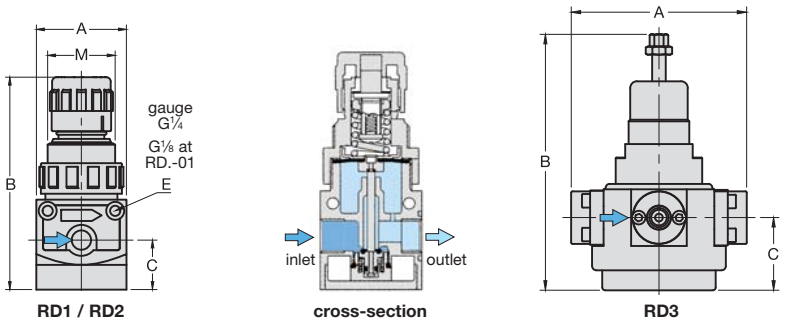

\*1 at 8 bar supply pressure, 6 bar outlet pressure and 1 bar pressure drop  
\*2 02 = 0...2.5 bar, 04 = 0...4 bar, 10 = 0...10 bar, 16 = 0...16 bar



<b>Description</b>	Good value pressure regulator of solid design. RD1 and RD3 are equipped with diaphragms, RD4 is piston-operated. Wall mounting through two drilled holes in the bodies of RD1 to RD3.
<b>Media</b>	compressed air or non-corrosive gases
<b>Supply pressure</b>	max. 30 bar
<b>Adjustment</b>	RD1/RD2: by plastic knob with snap-lock RD3: by handwheel RD4: by T-handle
<b>Relieving function</b>	relieving, optionally non-relieving
<b>Gauge port</b>	G $\frac{1}{4}$ on both sides of the body, G $\frac{1}{8}$ at RD1
<b>Mounting position</b>	any
<b>Temperature range</b>	-10 °C to 50 °C / 14 °F to 122 °F for RD1, RD2 and RD4 -20 °C to 60 °C / -4 °F to 140 °F for RD3
<b>Material</b>	Body: zinc die-cast at RD1, aluminium at RD2, RD3 and RD4 Spring cage: plastic reinforced with glass fibre at RD1, nylon at RD2, aluminium at RD3/RD4 Elastomer: NBR/Buna-N Inner valve: brass

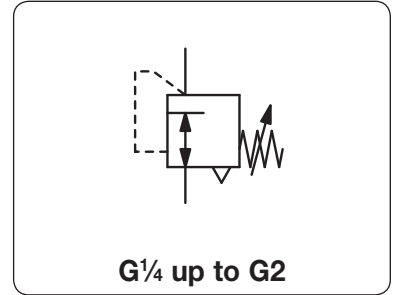

Dimensions			K <sub>v</sub> -value	Flow rate	P <sub>1</sub> max.	Connection thread	Pressure range	Order number
A	B	C						
mm	mm	mm	(m <sup>3</sup> /h)	m <sup>3</sup> /h*1	l/min*1	bar	G	bar

Pressure regulator								supply pressure max. 20 / 30 bar, relieving, without pressure gauge	RD1...RD4
215	385	130	18.6	1320	22 000	30	G $\frac{1}{2}$	0.2...1.5	RD4-12A
								0.3...3.0	RD4-12B
								0.5...8.0	RD4-12D
								1.5... 15	RD4-12E
215	385	130	18.6	1320	22 000	30	G2	0.2...1.5	RD4-16A
								0.3...3.0	RD4-16B
								0.5...8.0	RD4-16D
								1.5... 15	RD4-16E



**Special options, add the appropriate letter**

non-relieving without relieving function RD . . . . K  
30 bar operating pressure RD . . . . H

**Accessories**

pressure gauge	Ø 40 mm, 0...*2 bar, G $\frac{1}{8}$	for RD1	MA4001-..*2
	Ø 50 mm, 0...*2 bar, G $\frac{1}{4}$	for RD2	MA5002-..*2
	Ø 63 mm, 0...*2 bar, G $\frac{1}{4}$	for RD3 and RD4	MA6302-..*2
mounting bracket	made of steel	for RD1	BW30-02
mounting nut	made of plastic	for RD1	M30x1,5K
mounting bracket	made of steel	for RD2	BW50-03
mounting nut	made of plastic	for RD2	M50x1,5K
mounting bracket	made of steel	for RD3	BW00-06

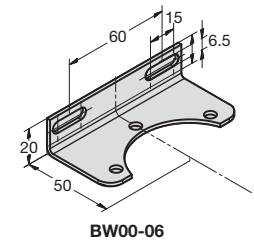
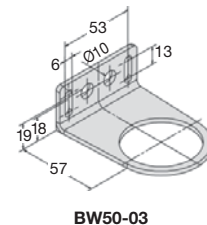
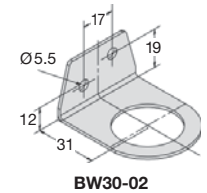

series	D	Ø E	M
RD1	30	4.5	M30x1,5
RD2	51	5.5	M50x1,5
RD3	76	6.5	-
RD4	76	8.5	-

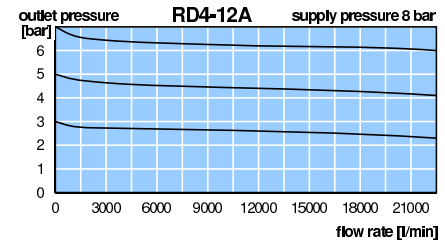
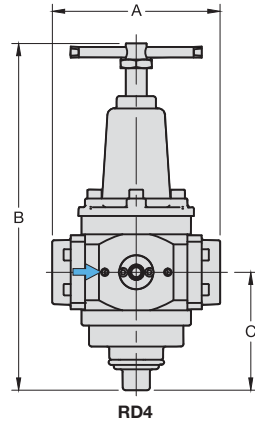

\*1 at 8 bar supply pressure, 6 bar outlet pressure and 1 bar pressure drop  
\*2 02 = 0...2.5 bar, 04 = 0...4 bar, 10 = 0...10 bar, 16 = 0...16 bar

<b>Description</b>	Diaphragm pressure regulator, with joint pressure supply. Modular assembly without need for double nipples or other fittings. Outlet at rear side, gauge port in the front.		
<b>Media</b>	compressed air or non-corrosive gases		
<b>Supply pressure</b>	max. 16 bar, max. 10 bar for R035		
<b>Air consumption</b>	without constant bleed		
<b>Adjustment</b>	by plastic knob with snap-lock, R035 without snap-lock		
<b>Relieving function</b>	relieving, optionally non-relieving		
<b>Gauge port</b>	G $\frac{1}{8}$ at R035 and RB-02, G $\frac{1}{4}$ at all others		
<b>Mounting position</b>	any		
<b>Temperature range</b>	0 °C to 50 °C / 32 °F to 122 °F		
<b>Material</b>	Body: zinc die-cast, POM at R035	Adjusting knob: plastic	Inner valve: brass
	Elastomer: NBR/Buna-N		
	Thread insert: brass at R035		

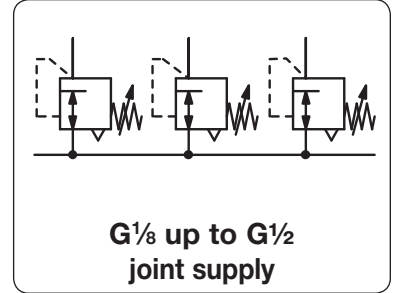

Dimensions			K <sub>v</sub> -	Flow	Connection	Pressure	Order
A	B	C	splitting value	rate	thread	range	number
mm	mm	mm	mm (m <sup>3</sup> /h)	m <sup>3</sup> /h*1 l/min*1	G	bar	

Pressure regulator		supply pressure max. 16 bar, relieving Series R035 max. 10 bar, without pressure gauge				RB / R035	
36	61	12	36	0.11	15	250	G $\frac{1}{8}$ 0 ... 6 <b>R035-01RB</b>
40	84	12	40	0.60	60	1000	G $\frac{1}{4}$ 0.1 ... 3 <b>RB-02B</b> 0.2 ... 6 <b>RB-02C</b> 0.5 ... 10 <b>RB-02D</b>
48	94	22	45	1.3	126	2100	G $\frac{1}{4}$ 0.1 ... 3 <b>RB-A2B</b> 0.2 ... 6 <b>RB-A2C</b> 0.5 ... 10 <b>RB-A2D</b> 0.5 ... 16 <b>RB-A2E</b>
58	114	27	55	1.9	192	3200	G $\frac{3}{8}$ 0.1 ... 3 <b>RB-03B</b> 0.2 ... 6 <b>RB-03C</b> 0.5 ... 10 <b>RB-03D</b> 0.5 ... 16 <b>RB-03E</b>
70	133	36	66	2.4	240	4000	G $\frac{1}{2}$ 0.1 ... 3 <b>RB-04B</b> 0.2 ... 6 <b>RB-04C</b> 0.5 ... 10 <b>RB-04D</b> 0.5 ... 16 <b>RB-04E</b>



## Accessories

<b>pressure gauge</b>	Ø 23 mm, 0... <sup>*2</sup> bar, G $\frac{1}{8}$	for RB-02 / R035	<b>MA2301-...<sup>*2</sup></b>
	Ø 40 mm, 0... <sup>*2</sup> bar, G $\frac{1}{4}$ , connection parts required	for RB-A2	<b>MA4001-...<sup>*2</sup></b>
	Ø 50 mm, 0... <sup>*2</sup> bar, G $\frac{1}{4}$	for RB-03 / RB-04	<b>MA5001-...<sup>*2</sup></b>
<b>connection parts</b>	adapter for MA4001, G $\frac{1}{4}$ m to G $\frac{1}{8}$ f		<b>VI-0201</b>
<b>mounting bracket</b>	made of steel	for RB-02 / RB-A2	<b>BW30-02</b>
<b>mounting nut</b>	made of plastic	for RB-02 / RB-A2	<b>M30x1,5K</b>
<b>mounting bracket</b>	made of steel	for RB-03	<b>BW00-25</b>
<b>mounting nut</b>	made of plastic	for RB-03	<b>M42x1,5K</b>
<b>mounting bracket</b>	made of steel	for RB-04	<b>BW50-03</b>
<b>mounting nut</b>	made of plastic	for RB-04	<b>M50x1,5K</b>
<b>connection clips</b>	made of plastic	for R035	<b>C350100018</b>
<b>connector kit</b>	for RB-02 <b>KP00</b>	for RB-03	<b>KP22</b>
	for RB-A2 <b>KP11</b>	for RB-04	<b>KP33</b>

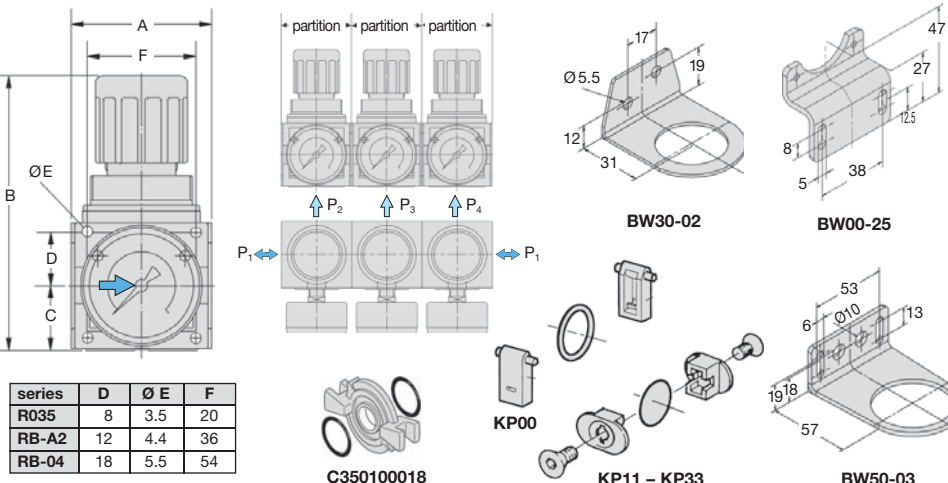

series	D	Ø E	F
R035	8	3.5	20
RB-A2	12	4.4	36
RB-04	18	5.5	54

\*1 at 8 bar supply pressure, 6 bar outlet pressure and 1 bar pressure drop  
\*2 04 = 0...4 bar, 06 = 0...6 bar, 10 = 0...10 bar, 16 = 0...16 bar

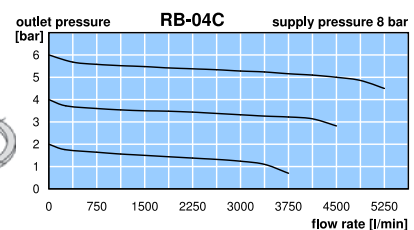
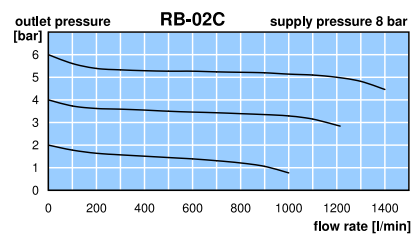

Gauges: see chapter for measuring devices

PDF CAD  
www.aircom.net

Order example:  
**R035-01RB**

# Gauge Pressure Regulator

RM

<b>Description</b>	Diaphragm-operated pressure regulator with integrated gauge in the handwheel. The regulator is user-friendly and saves on space for a gauge in panel.	
<b>Adjustment</b>	Knob with integrated gauge. The RM1 regulator has a tamper-proof knob with snap-lock.	
<b>Relieving function</b>	relieving as standard	
<b>Supply pressure</b>	RM1: max. 16 bar	RM2: max. 25 bar
<b>Pressure gauge</b>	RM1: scale in bar	RM2: scale in bar and psi readable down to 3 bar for 10/16 bar range
<b>Temperature range</b>	RM1: -10 °C to 60 °C / 14 °F to 140 °F	RM2: -10 °C to 90 °C / 14 °F to 190 °F
<b>Material</b>	RM1: body: zinc die-cast elastomer: NBR/Buna-N	RM2: body: zinc die-cast and aluminium elastomer: NBR/Buna-N

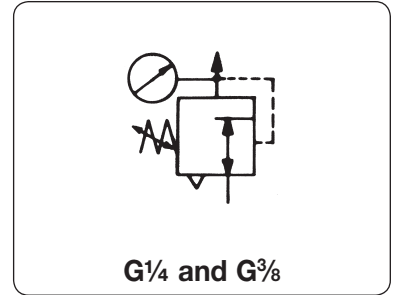

Dimensions			K <sub>v</sub> -value (m <sup>3</sup> /h)	Flow rate		Connection thread G	Pressure range bar	Order number
A	B	C		m <sup>3</sup> /h*1	l/min*1			

Pressure regulator, P <sub>1</sub> max. 16 bar							including nut, gauge range approx. 30% above pressure range	RM1
48	136	26	1.2	84	1400	G <sup>1</sup> / <sub>4</sub>	0.1... 3	RM1-02A
							0.2... 6	RM1-02B
							0.3...10	RM1-02C
48	136	26	1.3	90	1500	G <sup>3</sup> / <sub>8</sub>	0.1... 3	RM1-03A
							0.2... 6	RM1-03B
							0.3...10	RM1-03C



Pressure regulator, P <sub>1</sub> max. 25 bar							including nut, gauge range approx. 30% above pressure range	RM2
54	145	30	0.9	66	1100	G <sup>1</sup> / <sub>4</sub>	0.1... 3	RM2-02A
							0.2... 6	RM2-02B
							0.3...10	RM2-02C
							0.5...16	RM2-02D
54	145	30	1.0	72	1200	G <sup>3</sup> / <sub>8</sub>	0.1... 3	RM2-03A
							0.2... 6	RM2-03B
							0.3...10	RM2-03C
							0.5...16	RM2-03D

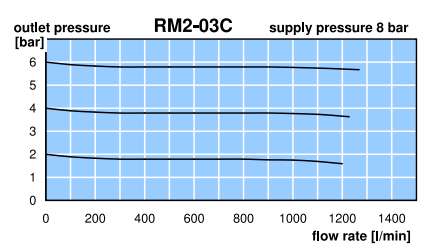
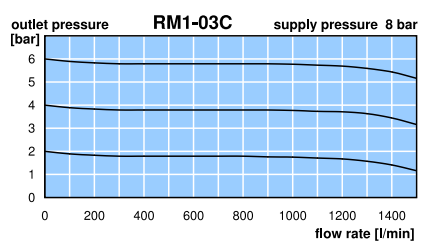
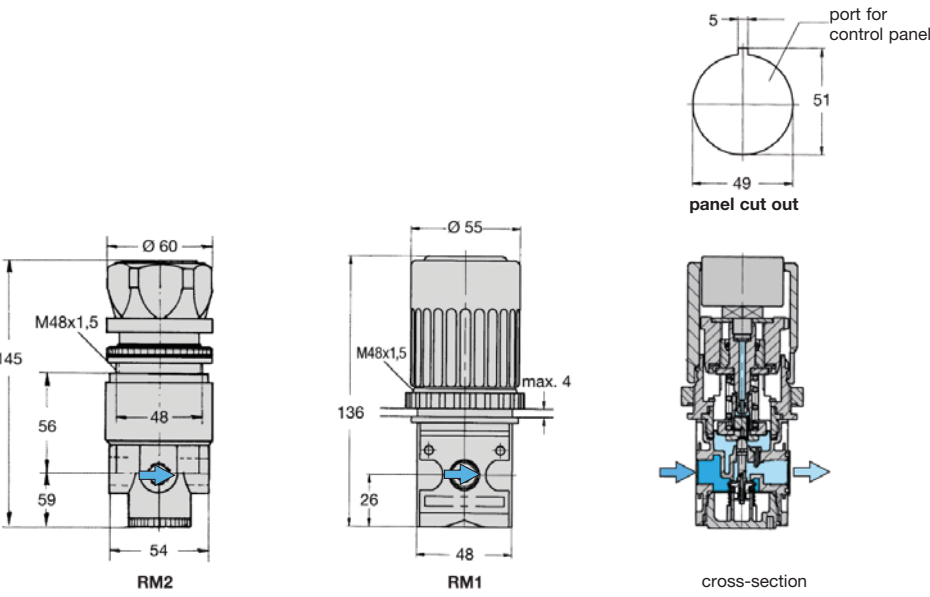

\*1 at 7 bar supply pressure, 6 bar outlet pressure and 1 bar pressure drop

# 270° Adjustment Dial Pressure Regulator, lockable

R11...R41

**Description** Piston-operated regulator with balanced valve design and high-relief flow. Features include a transparent pressure-calibrated, non-rising adjusting dial which can be mounted in any position so the dial face is always visible. Pressure setting in steps is possible.

**Media** compressed air

**Supply pressure** max. 21 bar, minimum 1 bar above outlet pressure

**Air consumption** R21/R31/R41: max. 1.4 l/min depending on outlet pressure R11: without constant bleed

**Adjustment** The full secondary pressure range can be dialed in less than a 270° turn proportional to handwheel with scale in bar or psi. This is advantageous if secondary pressure must be changed frequently.

**Relieving function** relieving

**Gauge port** G $\frac{1}{4}$  on both sides of the body, not available at R11

**Mounting position** any

**Temperature range** 0 °C to 65 °C / 32 °F to 149 °F

**Material** Body: zinc die-cast  
Piston: acetal  
Valve seat: acetal, brass and NBR/Buna-N  
O-ring: NBR/Buna-N

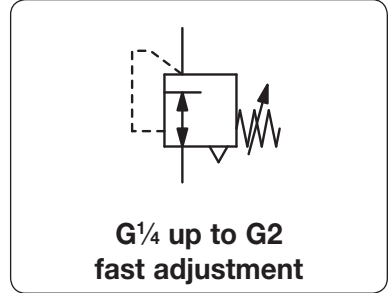

Dimensions			K <sub>v</sub> -value (m <sup>3</sup> /h)	Flow rate		Connection thread G	Pressure range bar	Order number
A mm	B mm	C mm		m <sup>3</sup> /h*1	l/min*1			

Adjustment dial regulator							supply pressure max. 21 bar, relieving, with constant bleed, adjusting dial 270° turn wheel		R11...R41
66	71	10	0.02	1.2	20	G $\frac{1}{4}$	0... 3	0... 11	R11-C2-L R11-C2-O
81	104	24	2.5	180	3000	G $\frac{1}{4}$	0... 3	0... 11	R21-C2-L R21-C2-O
81	104	24	3.8	270	4500	G $\frac{3}{8}$	0... 3	0... 11	R21-C3-L R21-C3-O
81	104	43	4.2	300	5000	G $\frac{1}{2}$	0... 3	0... 11	R21-C4-L R21-C4-O
109	132	43	6.8	480	8000	G $\frac{3}{4}$	0... 3	0... 11	R31-C6-L R31-C6-O
109	132	43	7.6	540	9000	G1	0... 3	0... 11	R31-C8-L R31-C8-O
135	173	71	18.5	1320	22000	G1 $\frac{1}{2}$	0... 3	0... 11	R41-CB-L R41-CB-O
135	173	71	20.0	1440	24000	G2	0... 3	0... 11	R41-CC-L R41-CC-O



**Special options, add the appropriate letter**

adjustment lock RRP-95-585 R. 1-C . . T

**Accessories**

pressure gauge Ø 50 mm, 0...\*2 bar, G $\frac{1}{4}$  for R21 to R41 MA5002-..\*2

mounting bracket mounting through the gauge port at the back for R21 to R41 RRP-95-590

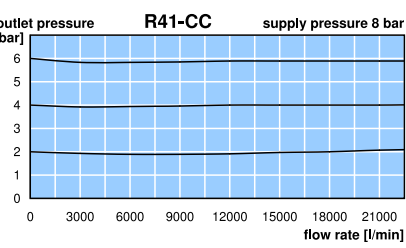
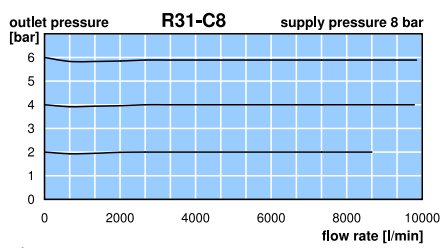
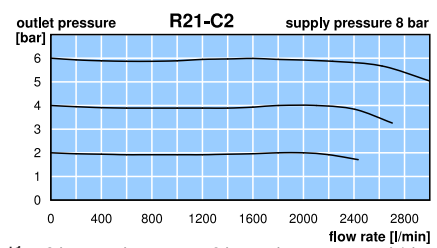
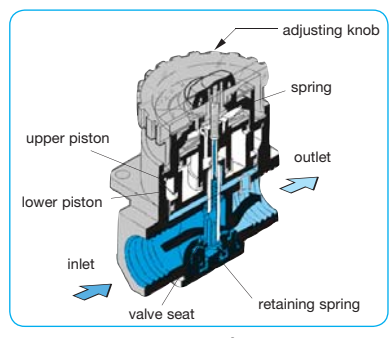
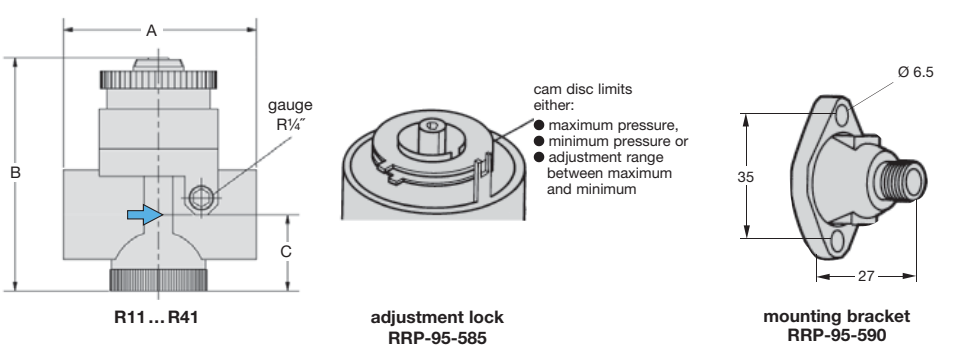

\*1 at 8 bar supply pressure, 6 bar outlet pressure and 1 bar pressure drop  
\*2 04 = 0...4 bar, 16 = 0...16 bar